

**25X
50X
100X**
MAGNIFICATION



36 PIECES

**FEATURES
ELECTRIC
ILLUMINATION**



Requires 2 x 1.5V AA batteries (not included).

WARNING!

To be used under the direct supervision of an adult.



The purpose of the crossed-out wheellie bin symbol is to remind us that most electrical product and batteries contain trace elements which could be harmful to our environment and therefore our health. We must all be careful to dispose of them responsibly in a specifically designated way – either using a collection scheme or into the correctly labelled civic amenity (NOT into general waste) – this will help your local authority to arrange to recycle or dispose of them in the appropriate manner.



Please retain the information on this manual for future reference.

Colour, designs and decorations may vary from those shown in the photographs.

Printed in China.

Trends UK LTD,
Greatworth Hall,
Banbury, OX17 2DH. UK
Email: trends@jgdirect.net

Inspired by **Discovery**
CHANNEL™

DiscoveryKIDS.com

© 2016 Discovery Communications LLC. Discovery kids and the Discovery Kids logo are trademarks of Discovery Communications, LLC, used under license. All Rights Reserved. discoverykids.com



www.trendsuk.co.uk

Item no. **TDK11**

Customer Services:
+44 (0)1702 208175

100X Microscope

Instruction Manual

Components

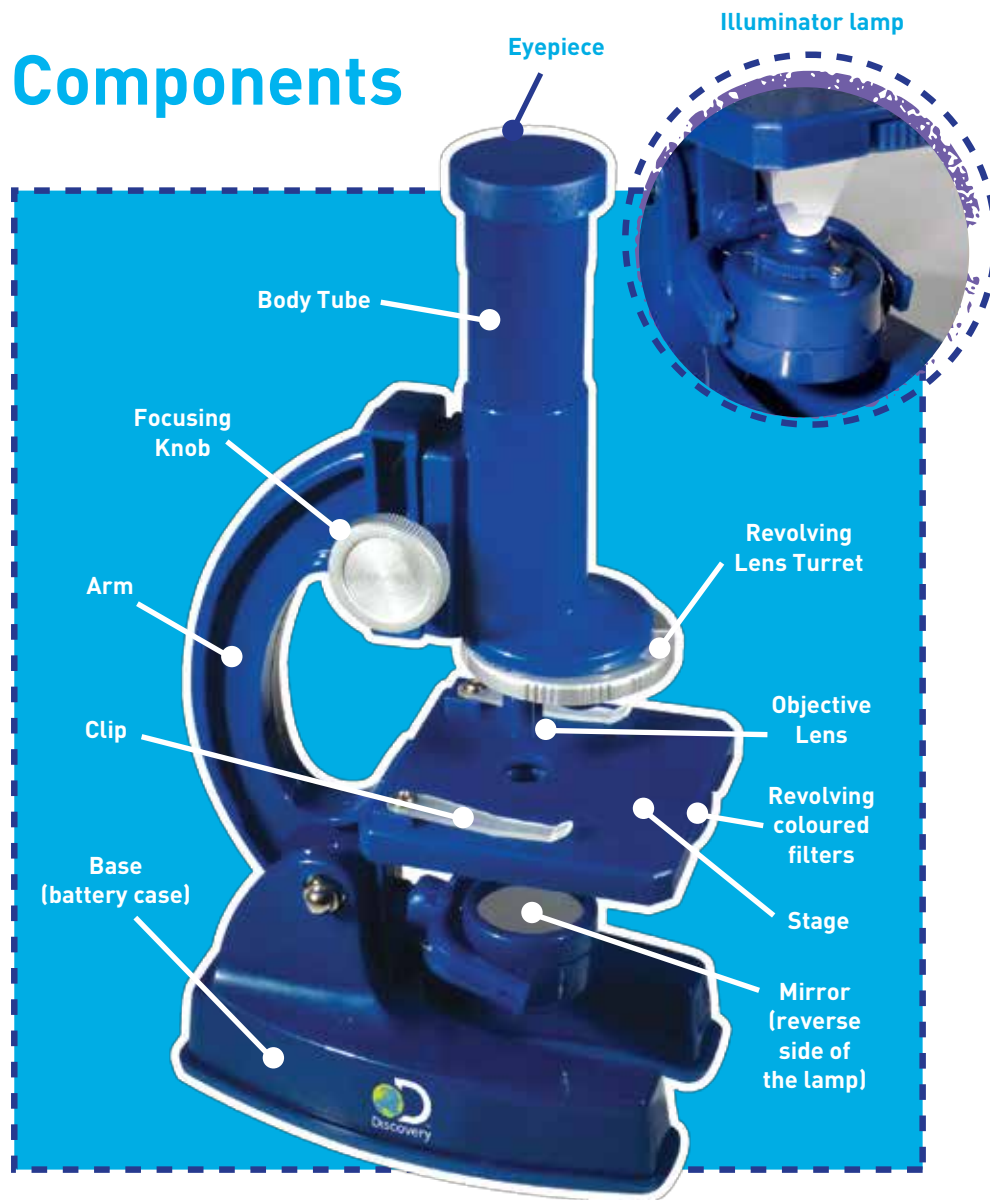

Contents

Features:

- 1 x microscope
- 1 x stirring rod
- 1 x tweezers
- 1 x spare bulb
- 3 x prepared slides (Fern root, wool and oleaster)
- 8 x blank slides
- 2 x vials
- 1 x magnifying glass
- 1 x pipette
- 1 x box containing:
8 x slide covers and labels
- 1 x manual

Things you may need for making slides that are not included with this set:

- Transparent glue
- Coloured dye (optional)

Helpful Hints

1. The most important parts of your microscope are the lenses. Handle them with care. If the lenses are dirty or dusty you can clean them with a soft cotton cloth or a special lens-cleaning tissue. Do not wipe them with a finger or a facial tissue.
2. If you are not going to use your microscope for a week or more, remove the two batteries that power the illuminator.
3. Protect your microscope from dust and moisture by always storing it in its box.



THIS 36-PIECE SET INCLUDES SLIDES, TOOLS AND ACCESSORIES FOR COLLECTING AND CREATING SPECIMENS

Getting Started

- 1) First read all the important battery information on page 6 before you start. Then turn the microscope over. Insert two AA alkaline batteries in the base of the microscope. In order to remove the bottom cover of the microscope you will need a Philips head screwdriver. Insert the batteries as shown, making sure that the (+) and (-) terminals are properly identified. Replace the bottom cover and reinsert the screw. Do not over-tighten.
- 2) Place the microscope on a flat surface near a bright light, or in the daytime or a window. Locate the mirror and adjust the angle so that when you look into the eyepiece you see a bright circle of light. Do not point mirror towards the sun, as eye damage may result. If there is no bright light available or if the room lighting is poor, you can use the microscope's electric illuminator. To turn on the illuminator, flip the mirror over so that the light bulb is aimed upward. The light will come on by itself.

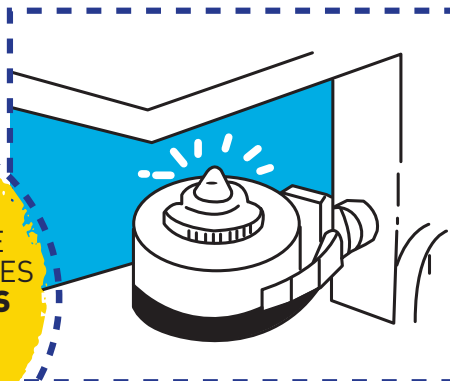
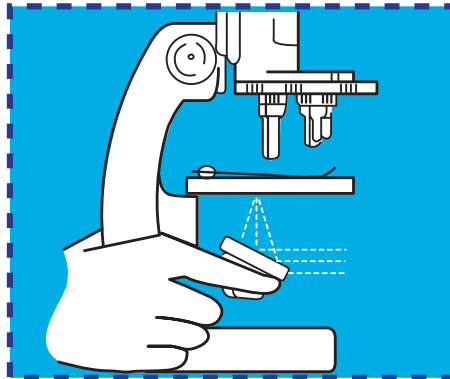
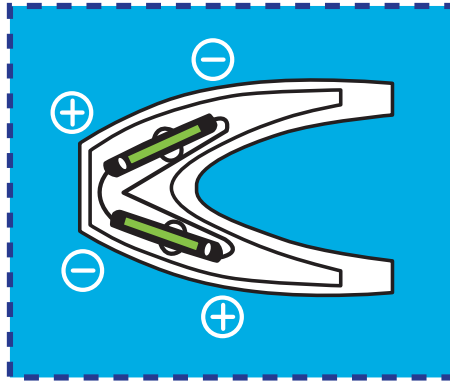

BEFORE LENSES WERE INVENTED, SOME EARLY MICROSCOPES USED TINY GLASS GLOBES FILLED WITH WATER TO MAGNIFY OBJECTS.

- 3) Once you can see a bright light circle in the eyepiece, your microscope is ready for use.
- 4) Choose one of the prepared sample slides from your set. Place it under the two spring clips on top of the stage.
- 5) Next, choose the magnifying power you want to use. Your microscope can provide magnifying powers of 25X, 50X and 100X
- 6) To change the magnifying strength, turn the revolving lens turret until you hear a click.
- 7) Turn the focusing knob until the objective lens is almost touching the slide. Don't let the lens touch the slide, as you may break the slide and damage the lens. Now look through the eyepiece and slowly turn the focusing knob back until you see the sample clearly.
- 8) Try using one of the coloured filters, as they can improve the image of particular specimens.

IMPORTANT: Wash your hands before and after every project using warm water and soap. Also wash any of the tools and accessories that have been used to prepare specimens. Be careful when handling the slides and slide covers. Make sure an adult knows what you are doing and is available to help you.

YOUR MICROSCOPE IS LIT WITH A SMALL BATTERY OPERATED BULB. A SYNCHROTRON PARTICLE ACCELERATOR PRODUCES X-RAYS THAT ARE 100 MILLION TIMES BRIGHTER THAN THE SUN. A BIT BIG TO CARRY AROUND THOUGH!

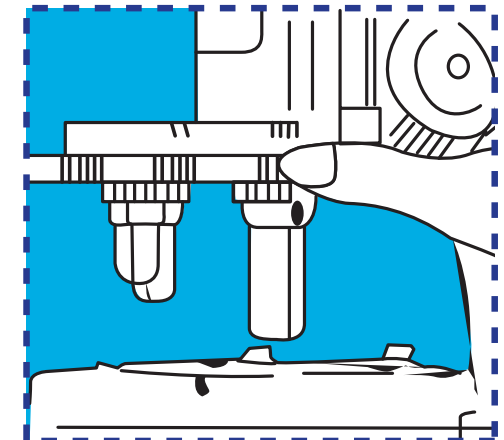
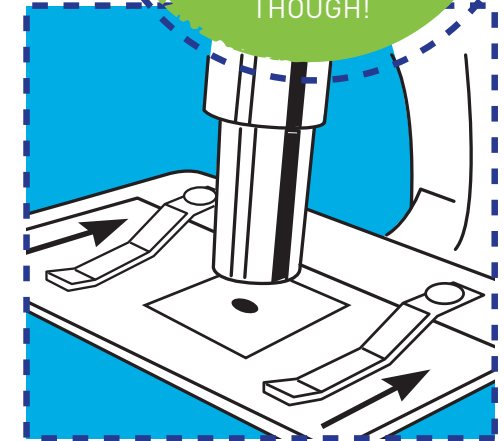

How To Prepare A Slide

Samples for examination should be very thin so that light can pass through them. If the sample is too thick it will appear dark in the microscope.

Cloth fibres, pollen, dust or salt crystals will be easy to see and make good samples for beginners to observe.

If the sample is very thin and clear a drop of dye may make details show more clearly. Methylene blue dye (not included) can be obtained from an aquarium supply store. You can transfer a drop of dye from the bottle to your slide with the pipette.

Collecting Specimens

Use your tweezers and the vials to collect very small specimens from your garden or home. Items that are good to look at under a microscope are pieces of bath sponge, leaves, plant roots, flower stems, sand, dirt, fabric fibres, salt and seeds.

Making A Temporary Slide

1. Wipe a blank slide clean, as dirt or grease may affect the viewing of your specimen.
2. Prepare a thin sample. You may have to ask an adult to slice something for you, as knives and scissors can be sharp.



You can also try a little food colouring to see if that works on your specimen. Try mixing up your own colours using different food colours, an empty vial and the stirring rod included in the set.

Remember they must be thin enough and small enough so that the light can shine through and all around them up through the hole of the slide. Solid objects are not good for viewing with your microscope.

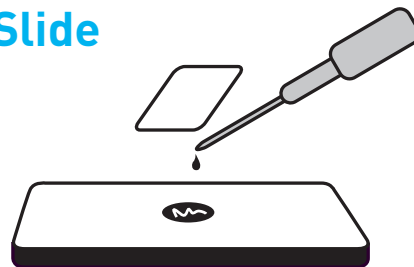

Cross-sections of stems, roots and pieces of leaves are really interesting under the microscope. When any kind of cutting is involved, adult supervision is essential.

3. Pick up your sample with the tweezers and put it on the centre section of the slide. Add one drop of water or, if needed, you can now add a drop of dye/food colouring using your pipette.

4. Gently place a slide cover (see-through plastic label) over the sample, being careful not to allow in any air bubbles.
5. Remove any excess water or dye/food colouring with a piece of paper towel (not included) by pressing it down gently over the slide cover.
6. Observe your slide.

Making A Permanent Slide

1. Start with a clean slide and slide cover. Make sure your hands are clean and dry when handling the slide covers.
2. Follow Steps 2 and 3 as before.
3. Before placing the slide cover over your specimen add several drops of transparent glue (not included). Caution! Always follow the safety instructions on glue bottles.

4. Place the slide cover gently over the sample and gently squeeze out any air bubbles.
5. Place your new slide in a safe place and let it dry for a day before you observe it under the microscope.

We have also supplied labels for your slides so you can name specimens for future reference.

Important Information – Safe Battery Usage

- Only adults should replace batteries.
- Do not mix battery types or old and new batteries.
- Do not use rechargeable batteries.
- Non-rechargeable batteries are not to be recharged.
- Batteries are to be inserted with the correct polarity.
- Do not short-circuit the supply terminals.
- Remove exhausted batteries from the toy.

- When the toy is not in use, remove batteries to prevent possible leakage.
- Use only recommended or equivalent battery types.
- Do not dispose of batteries in fire: batteries may explode or leak.

